

HONDA
ENGINES

GX 620 K1

Horizontal shaft gasoline (petrol) engine

- Moteur à essence à arbre de sortie horizontal
- Benzinmotor mit horizontaler Kurbelwelle
- Motore a benzina ad albero orizzontale



14.7 kW (20 HP) / 3 600 min⁻¹

Dimensions Unit: mm (in.)

STANDARD TYPE

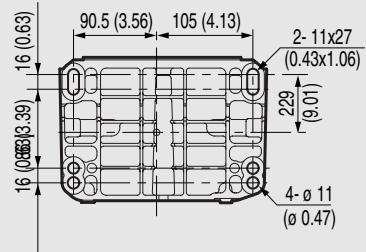
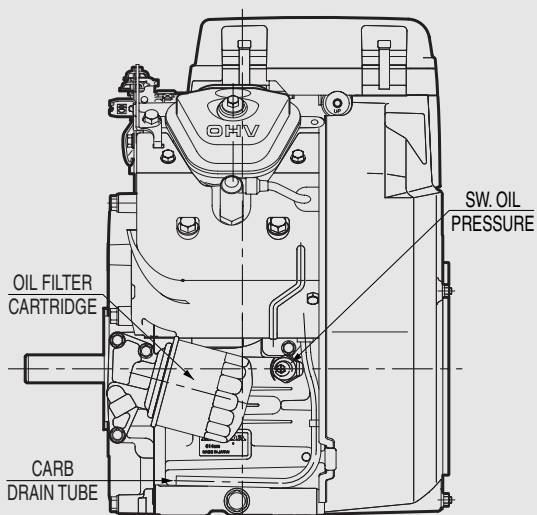
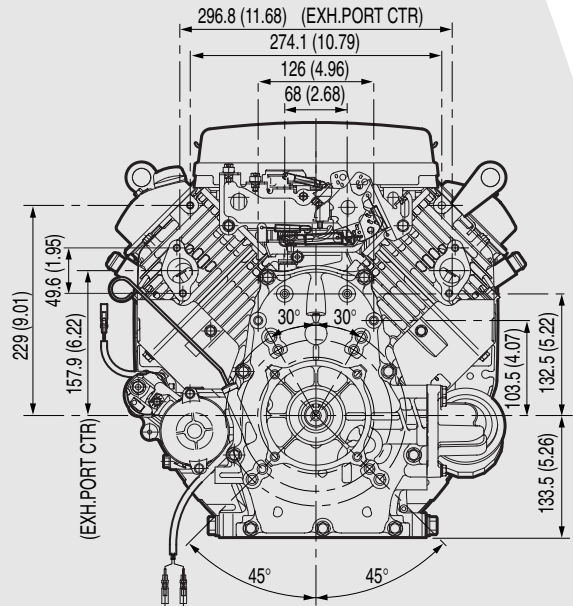
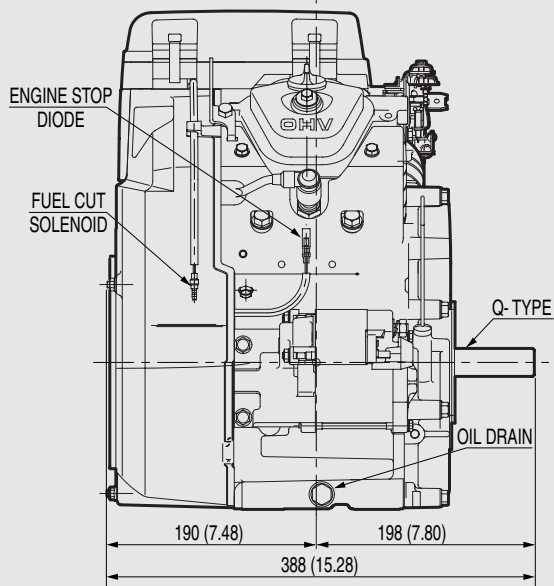
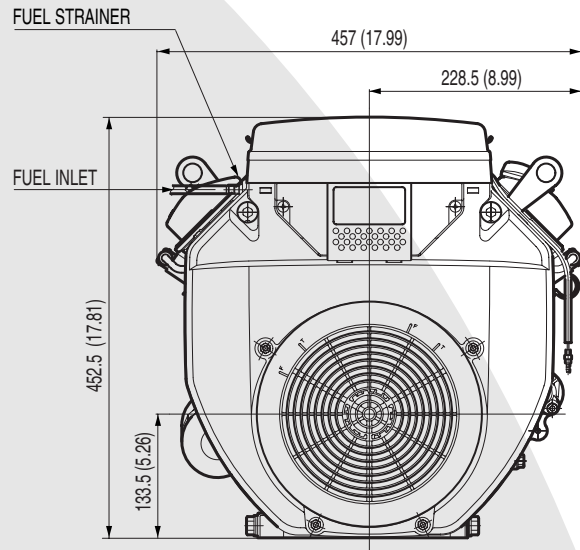
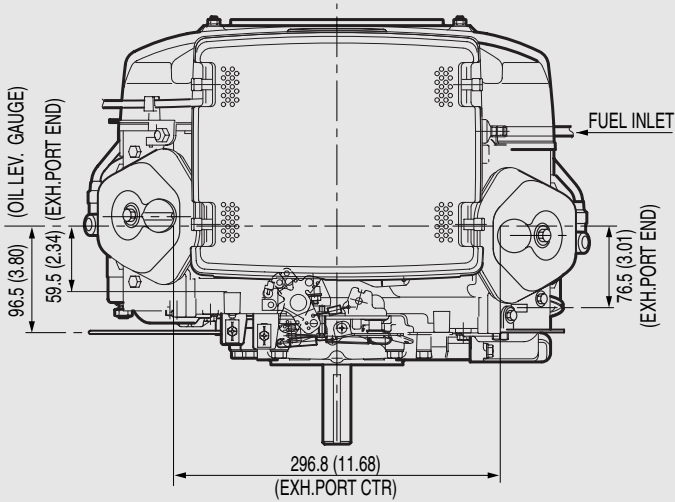

POWERED by
Honda Engines

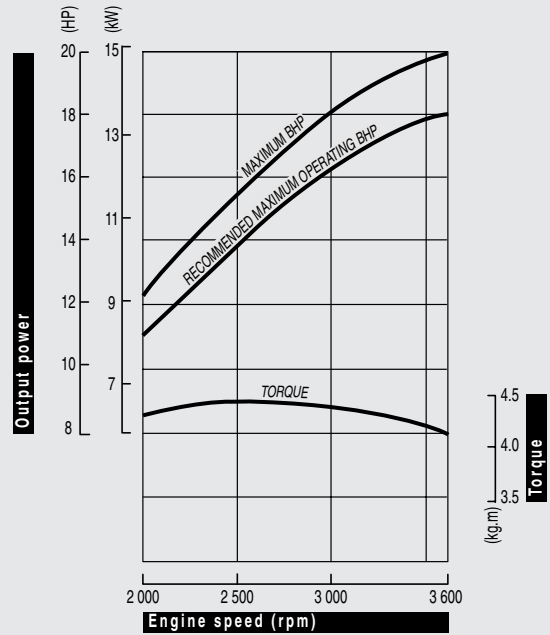
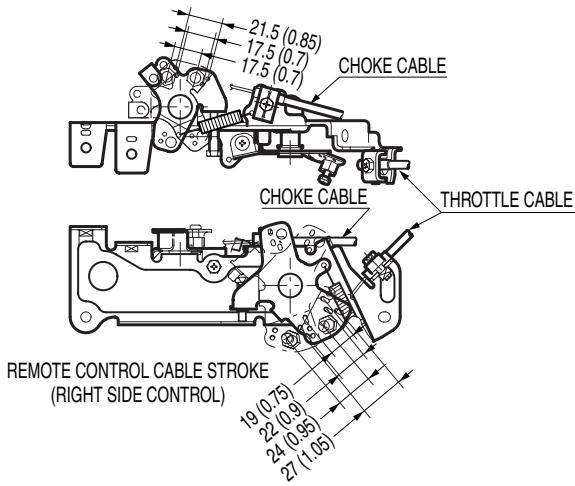
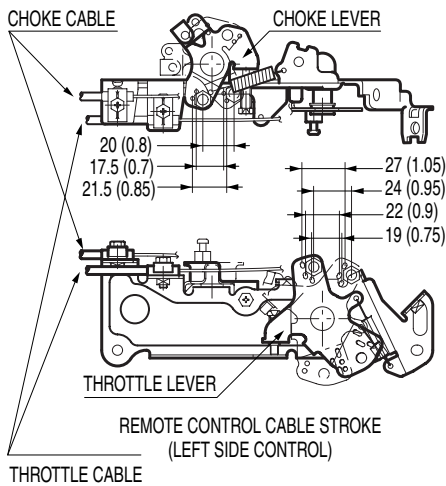

Performance curve

Horsepower rated in accordance with SAE J1995 (Gross)

For continuous operation, the BHP load should be less than 85% of maximum BHP

Courbe de puissance

Puissance mesurée selon SAE J1995 (Gross)

Pour une opération continue, la charge devrait être moins de 85% de la courbe "maximum BHP"

Leistungsangabe

Leistung gemessen nach SAE J1995 (Gross)

Für Dauerbetrieb sollte die Last weniger als 85% der "maximalen Leistungsangabe (max. BHP)" sein.

Curva di potenza

Potenza in conformità allo standard SAE J1995 (Gross)

Per uso continuativo, la potenza prelevata dovrà essere del 85% inferiore, rispetto a quella indicata nella curva "maximum BHP".

PTO SHAFT DIMENSIONS

Q-TYPE

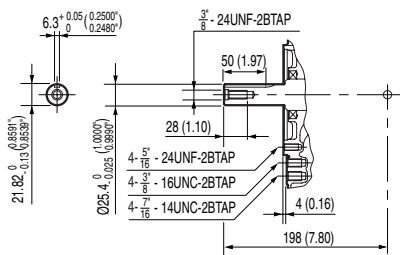

V-TYPE

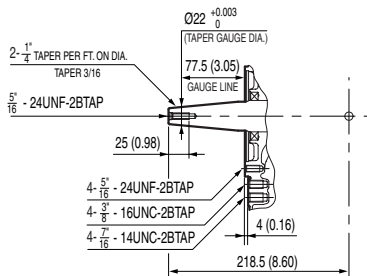

GX 620 K1



Specifications

Model	GX 620 K1
Engine type	Air cooled 4 stroke OHV petrol engine, 90° V-twin design, horizontal shaft
Bore x stroke	77 x 66 mm
Displacement	614 cm ³
Compression ratio	8.3 : 1
Max. power output	14.7 kW (20 HP) / 3 600 rpm
Maximum torque	44.1 Nm / 4.5 kgm / 2 500 rpm
Ignition system	Transistorised
Starting system	Electric starter
Specific fuel cons.	313 g/kW.hr - 230 g/HP.hr
Engine oil capacity	1.8 l
Dimensions (L x W x H)	388 x 457 x 452 mm
Dry weight	42 kg

Spécifications techniques

Modèle	GX 620 K1
Type du moteur	Moteur à essence bicylindre 4 temps OHV, refroidissement à air, cylindres en V de 90°, arbre de sortie horizontal
Alésage x course	77 x 66 mm
Cylindrée	614 cm ³
Taux de compression	8.3 : 1
Puissance maxi	14.7 kW (20 ch) / 3 600 tr/mn
Couple maximal	44.1 Nm / 4.5 kgm / 2 500 tr/mn
Système d'allumage	Transistorisé
Système de démarrage	Démarrreur électrique
Cons. d'essence spéc.	313 g/kW.h - 230 g/ch.h
Capacité d'huile moteur	1.8 l
Dimensions (L x l x H)	388 x 457 x 452 mm
Poids à sec	42 kg

All specifications are subject to change without notice.
Les caractéristiques techniques peuvent être modifiées à tout moment et sans préavis.

Spezifikationen

Modell	GX 620 K1
Motortyp	Luftgekühlter 2-Zylinder 4-Takt OHV Benzinmotor, 90° V-Twin, horizontale Kurbelwelle
Bohrung x Hub	77 x 66 mm
Hubraum	614 cm ³
Verdichtung	8.3 : 1
Höchstleistung	14.7 kW (20 PS) / 3 600 min ⁻¹
Max. Drehmoment	44.1 Nm / 4.5 kgm / 2 500 min ⁻¹
Zündsystem	Elektronische Zündung
Starter	Elektrostarter
Spez. Kraftstoffverbrauch	313 g/kWh - 230 g/PSH
Motorölkapazität	1.8 Liter
Maße (L x B x H)	388 x 457 x 452 mm
Trockengewicht	42 kg

Dati tecnici

Tipo	GX 620 K1
Tipo di motore	Motore bicilindrico OHV ad albero orizzontale ciclo otto, 4 tempi, cilindri disposti a V di 90° raffreddamento ad aria forzata
Alesaggio x corsa	77 x 66 mm
Cilindrata	614 cm ³
Rapporto di compressione	8.3 : 1
Potenza massima	14.7 kW (20 CV) / 3 600 giri/min
Coppia massima	44.1 Nm / 4.5 kgm / 2 500 giri/min
Accensione	A transistor senza contatti
Avviamento	Elettrico
Consumo combustibile	313 g/kWh - 230 g/CVh
Capacità coppa olio	1.8 l
Dimensioni (Lu x La x A)	388 x 457 x 452 mm
Peso a secco	42 kg

Le specifiche sono soggette a cambiamento senza preavviso.
Die Spezifikationen können ohne Vorankündigung geändert werden.

Ref. EEC - TS 2001/08 - GX 620 K1

honda@iohta.com

Germany • Honda Engines / Selling agent
Honda Logistik Center Deutschland GmbH
Spendingler Landstraße 166
D-63069 Offenbach/Main
TEL: + 49 (0)6 98 30 95 17
FAX: + 49 (0)6 98 30 91 28

United Kingdom • Honda Engines / Selling agent
Honda Logistics Centre (UK) Ltd.
Unit 3210, Wellington Parkway,
Magna Park Lutterworth,
Leicestershire LE 17 4JQ United Kingdom
TEL: + 44 (0)1 45 55 59 429
FAX: + 44 (0)1 45 55 59 428

HONDA
ENGINES

Honda Europe NV
EUROPEAN ENGINE CENTER
Langerbruggestraat 104 • B-9000 Gent
TEL: + 32 (0)9 250 12 11 • FAX: + 32 (0)9 250 14 24

Italy • Honda Engines / Selling agent
Honda Logistic Centre Italy S.P.A.
Via Strà, 153
I-37030 Colognola ai Colli (VR)
TEL: + 39 04 56 17 33 41
FAX: + 39 04 56 15 12 70

France • Honda Engines / Product information center
Parc d'Activités de Pariest
Allée du 1er Mai
Croissy Beaubourg
F-77313 Marne-La-Vallée Cedex 13
TEL: + 33 (0)1 60 37 31 18
FAX: + 33 (0)1 60 37 33 66